

T

DYSZE O SZCELINACH PIONOWYCH FILTER NOZZLES WITH VERTICAL SLOTS



- Uniwersalna
- Szeroka powierzchnia filtrująca
- Połączenie mocnej i nowoczesnej konstrukcji z ekonomicznym rozwiązaniem
- Pełny zakres gwintów i trzonek

- Multipurpose
- Wide filtering area
- Strong and inexpensive
- Complete set of thread and stem

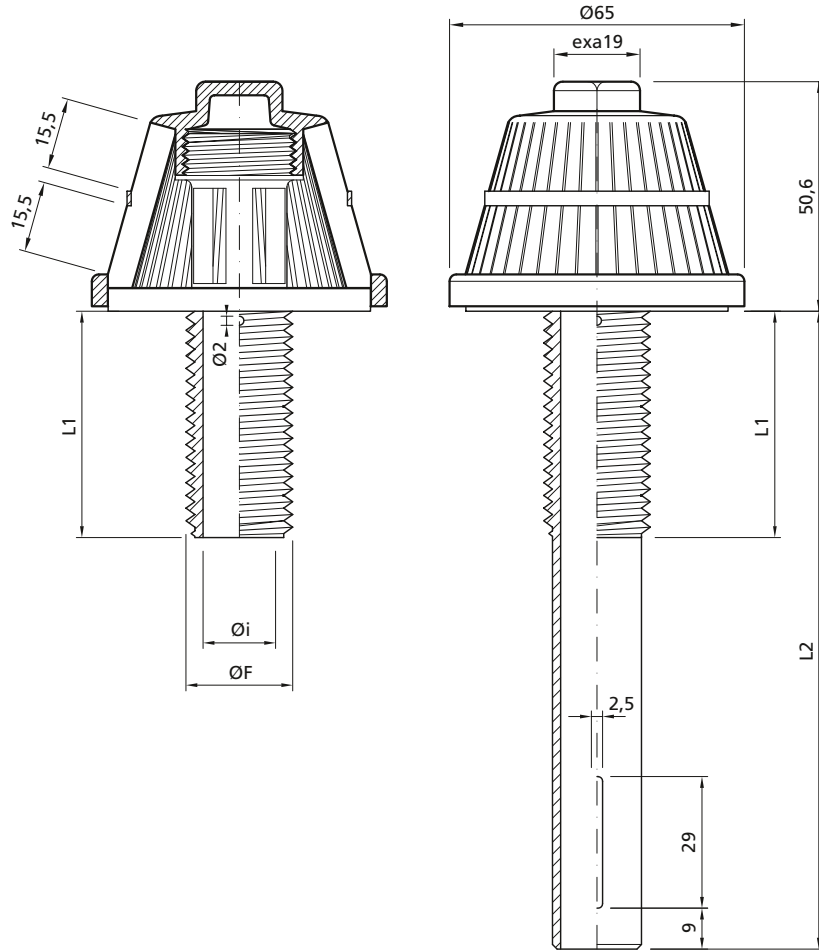

Typ Type	Szczelina Slot width mm	Ilość szczelin Slots No.	Powierzchnia szczelin Area mm ²
T	0,25	40	310
	0,5	40	620

Material/Material: PP - PPFV - PVDF

Gwint Thread	ØF mm	Øi mm	Powierzchnia trzonka Stem area mm ²	L1 mm	L2 mm
3/4"G	26.4	16	200	20, 30, 50	50, 160, 200, 250, 280
M24	24	16	200	20, 30, 50	50, 80, 100, 120, 140
15/16"W	23.5	16	200	20, 30, 50, 120	50, 80, 100, 120, 140, 160, 200, 250, 280
1"W	25.4	16	200	20, 30, 50	50, 80, 100, 120, 140, 160, 200, 250, 280
1.1/4"W	31.75	21,5	363	30, 50, 65	50, 160, 200, 250, 280, 300,, 450

